

ALL SPECIFICATIONS SUBJECT TO CHANGE WITHOUT NOTICE

FEATURE	DESCRIPTION	SPECIFICATION
Capacity	Tilt Out Bag Cage	7-1/2 cu.ft. 55 US Gallons (210L)
	Poly Bag	2.5 mil 30 x 38 (760 x 965)
	Optional Polyethylene Liner	Reusable
Construction	Housing	14 Ga. (1.9) Galvanneal Steel
	Floor	12 Ga. (2.6) Galvanneal Steel
	User Door	14 Ga. (1.9) Galvanneal Steel
	Side Hinged Unloading Door	12 Ga. (2.6 Galvanneal Steel
	Hinges and Latches	Stainless Steel
	Paint	Powder Coat
	Siding	Recycled Plastic
Weights	Freedom Container w/o Siding Kit	225lbs (102kg)
	Freedom Container c/w Siding Kit	325lbs (145kg)
	(Optional) Pre-Cast Mounting Pad (HBI-572)	345lbs (155kg) 36x28x4 (915x710x102)

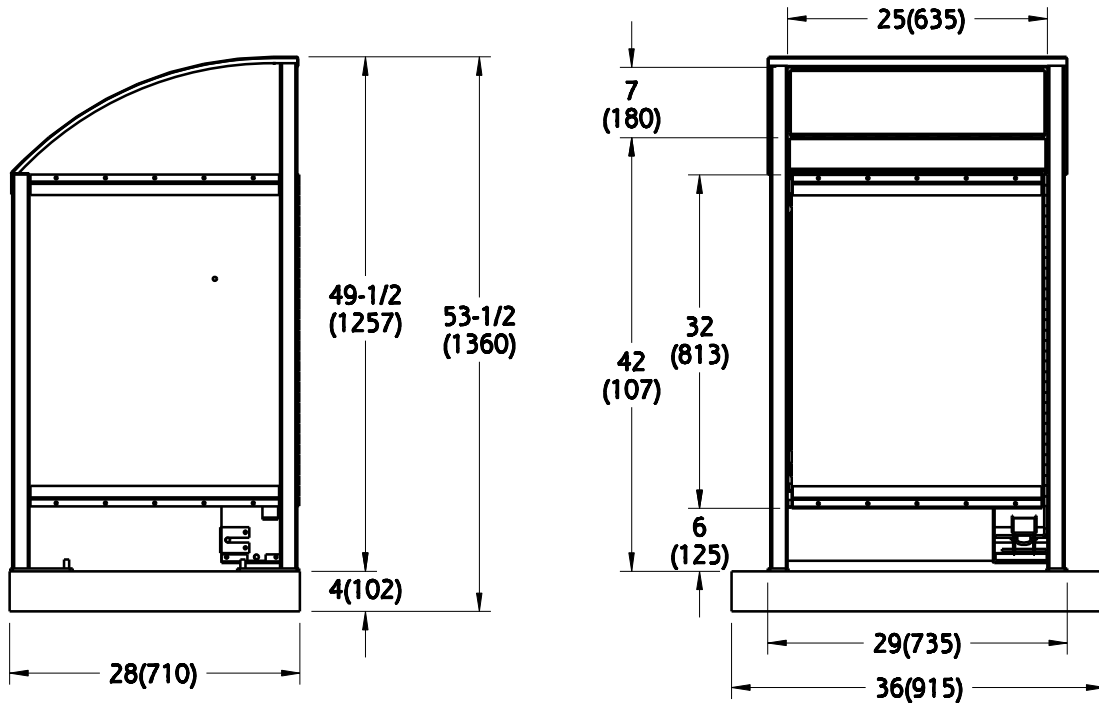

MOUNTING PAD (OPTIONAL)

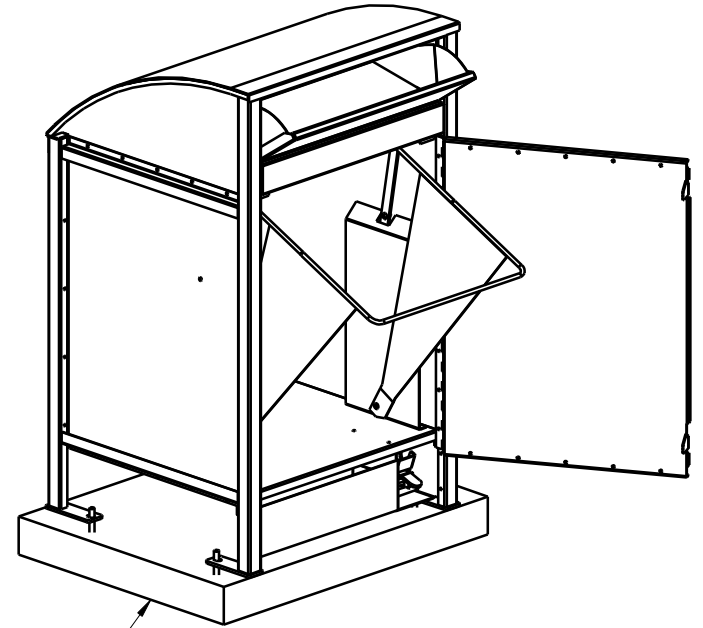
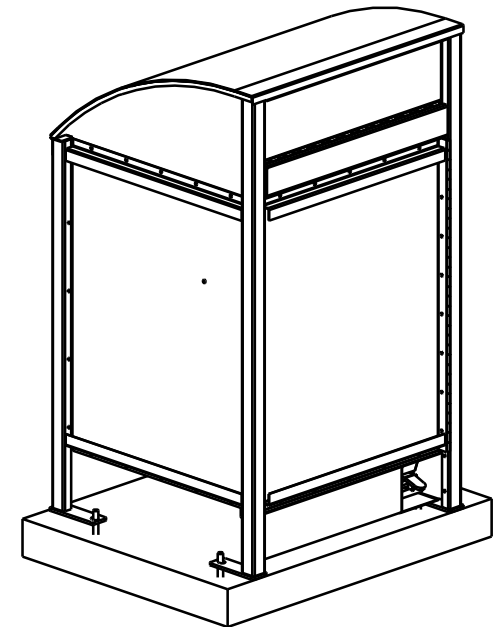

NOTE: ALL DIMENSIONS INCHES (MILLIMETERS)

TRAILER SIZE	QTY
8-1/2ft x 45ft	45
8-1/2ft x 53ft	54
B-Train 8-1/2ft x 28ft & 32ft	60
Double Decker Van 8-1/2ft x 48ft	96

HAUL-ALL EQUIPMENT LTD. reserves proprietary rights on this drawing or any part of the information contained thereon. This drawing shall be considered confidential material and is not to be used for competitive bidding nor for use in any procurements other than from Haul-All Equipment Ltd.



NAME		FREEDOM 55 CONTAINER	
PART NUMBER		SP-HF55A	DRAWN BY PS
DATE		FEBRUARY 28, 2013	REVISION 1